

OUTLET STRUCTURE DESIGNATION	W (FT)	L (FT)	SIZE OF ROCK	MIN ROCK DEPTH (D)
B	11.75	8.0	R-5	27"
C	17.5	13.0	R-5	27"

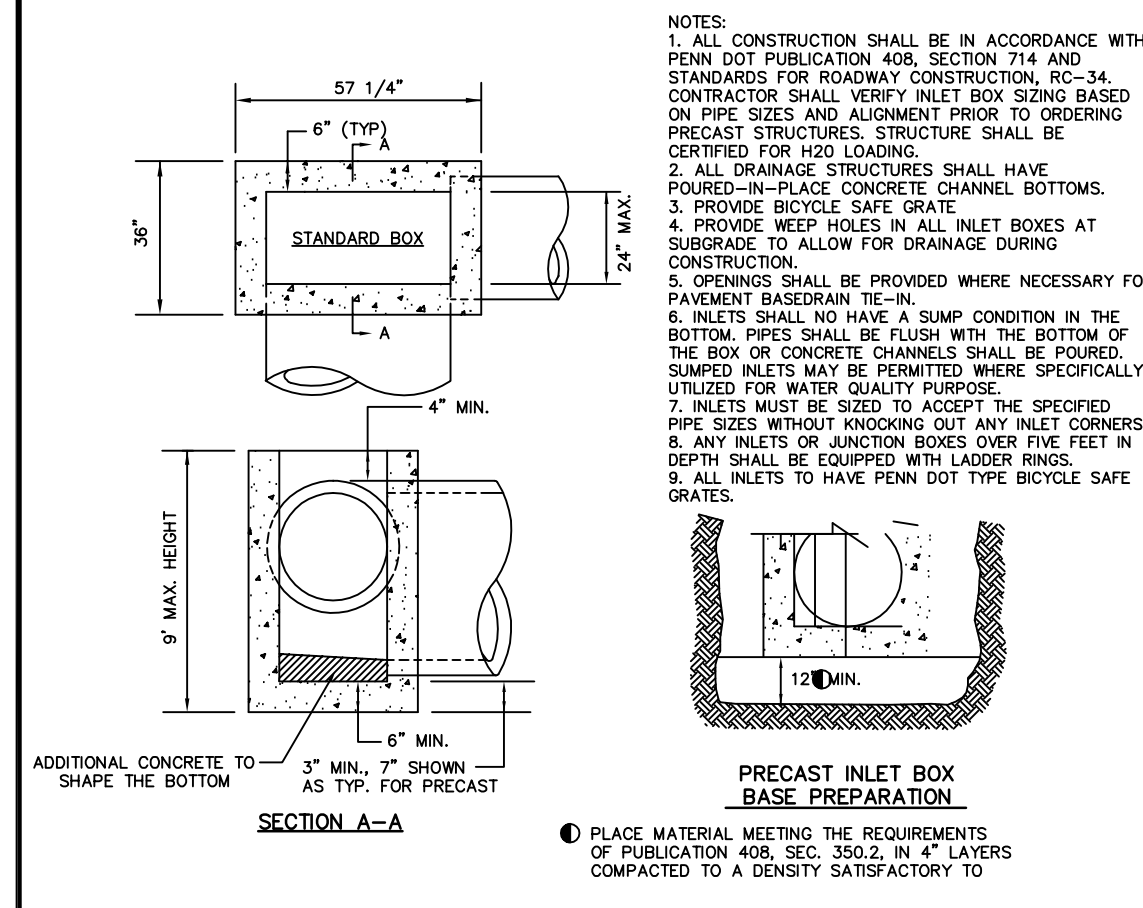
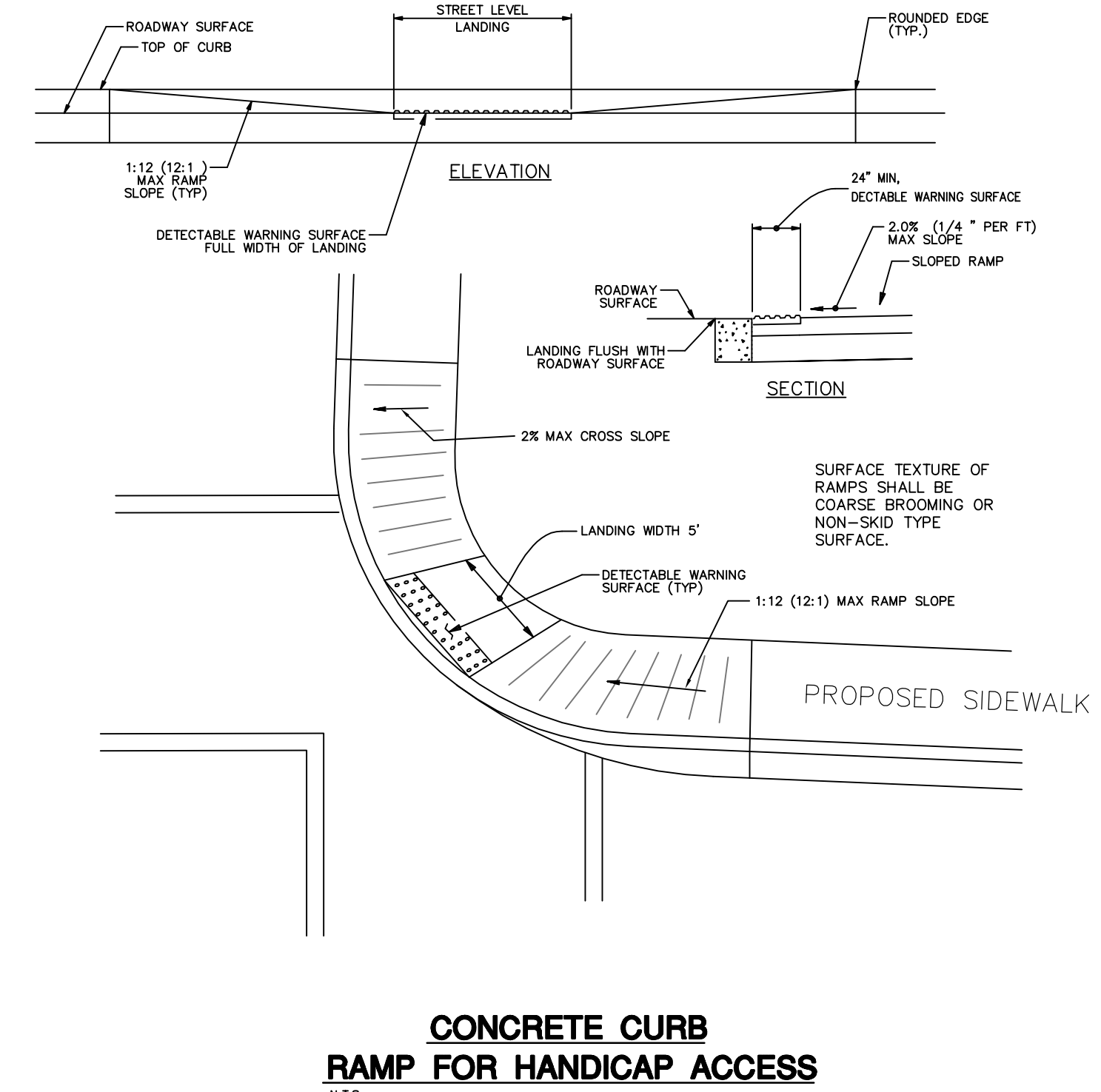
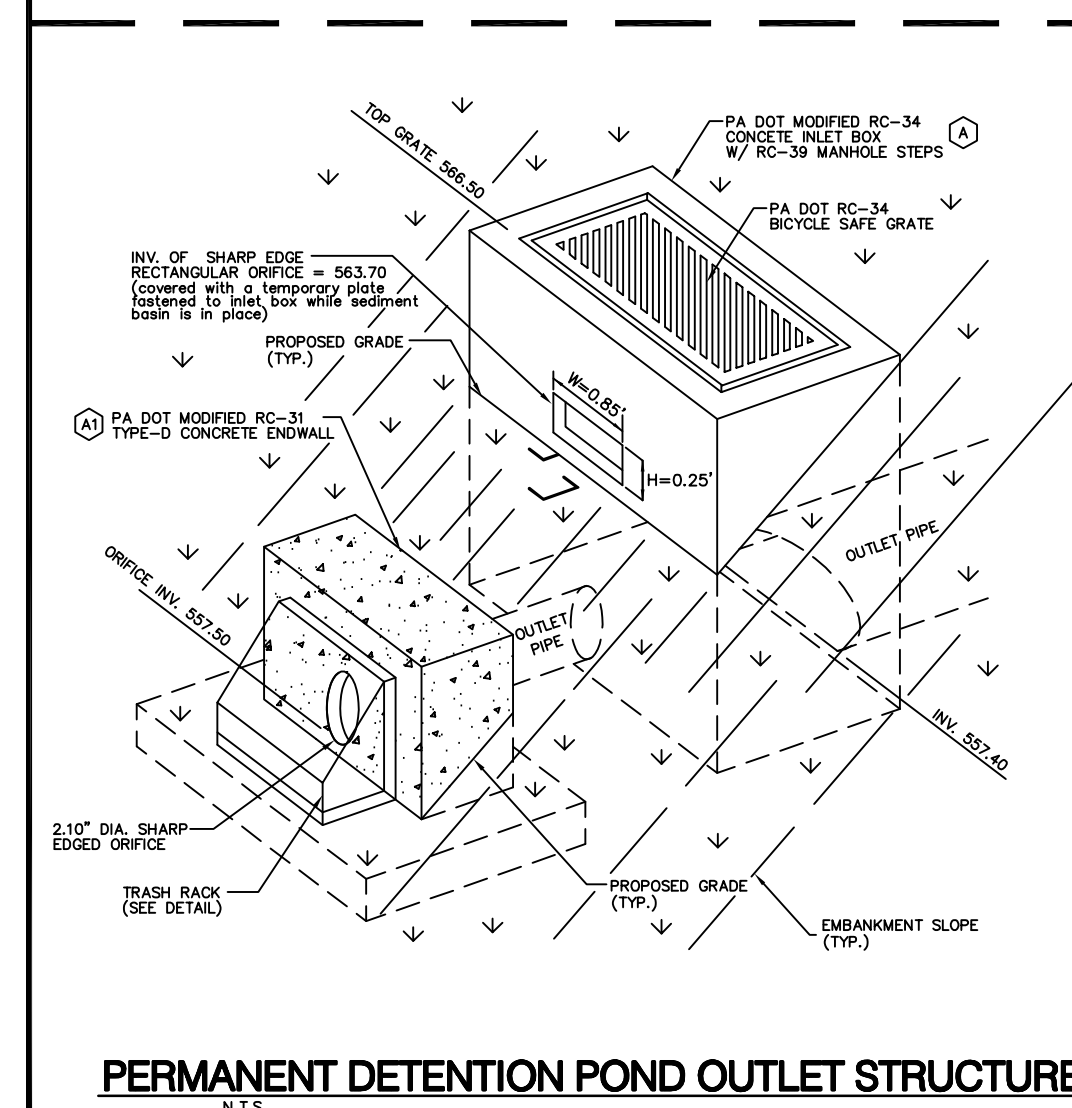
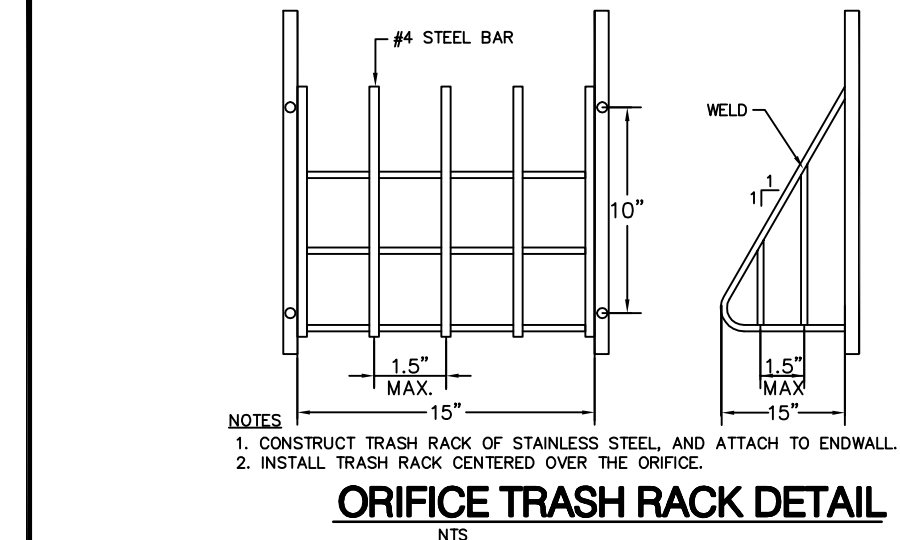
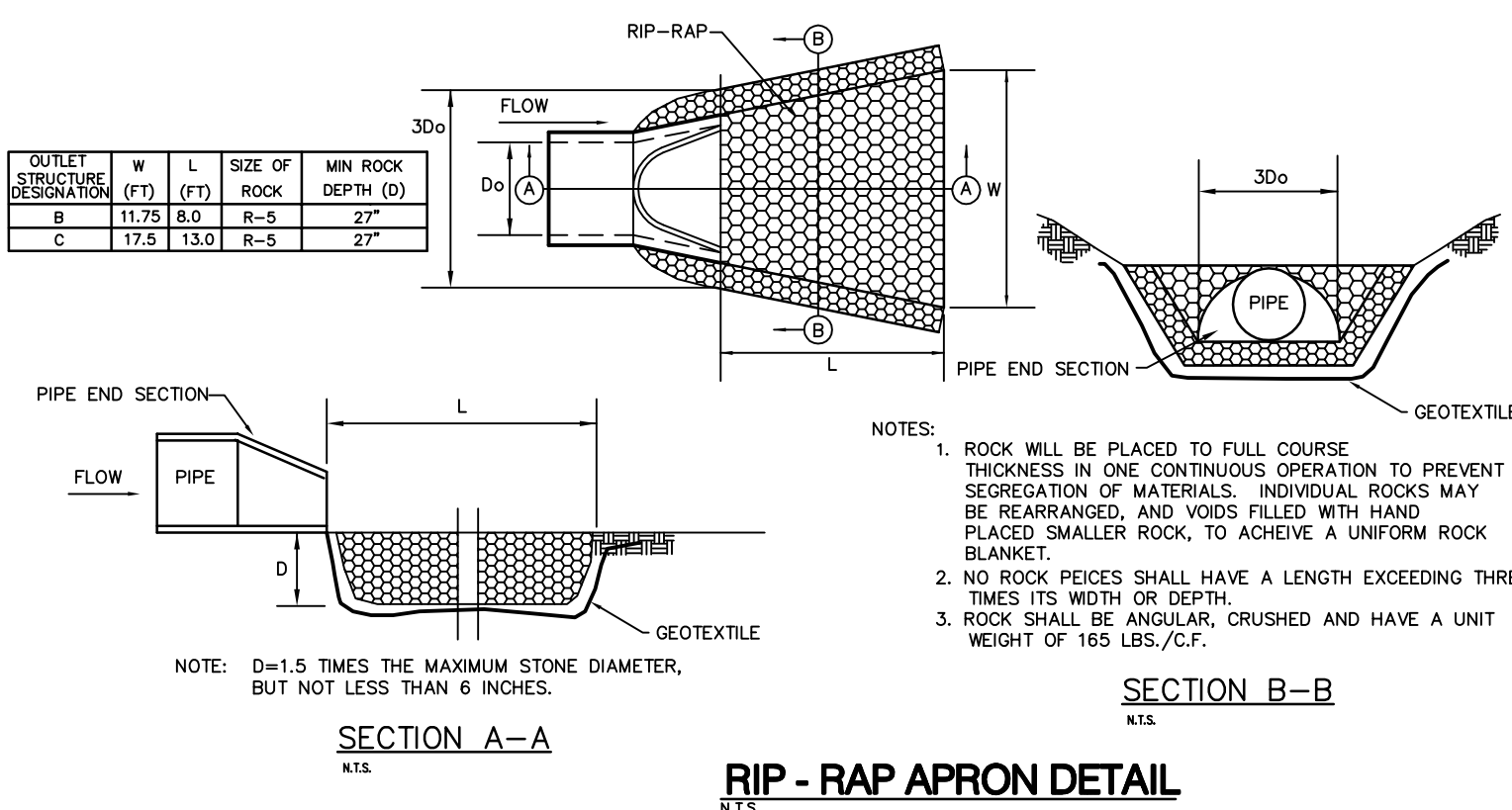

R. J. FISHER & ASSOCIATES, INC.

LAND PLANNING & DEVELOPMENT DESIGN ■ PROPERTY & TOPO. SURVEYS
LANDSCAPE ARCHITECTURE ■ WETLANDS IDENTIFICATION & DELINEATION

1546 BRIDGE STREET, NEW CUMBERLAND, PA. 17070
(717) 774-7534 FAX (717) 774-7190

COPYRIGHT © 2010 BY R.J. FISHER & ASSOCIATES, INC.

DATE	REVISION	BY	CHKD
08/29/21	1		
	2		
	3		
	4		
	5		
	6		
	7		
	8		

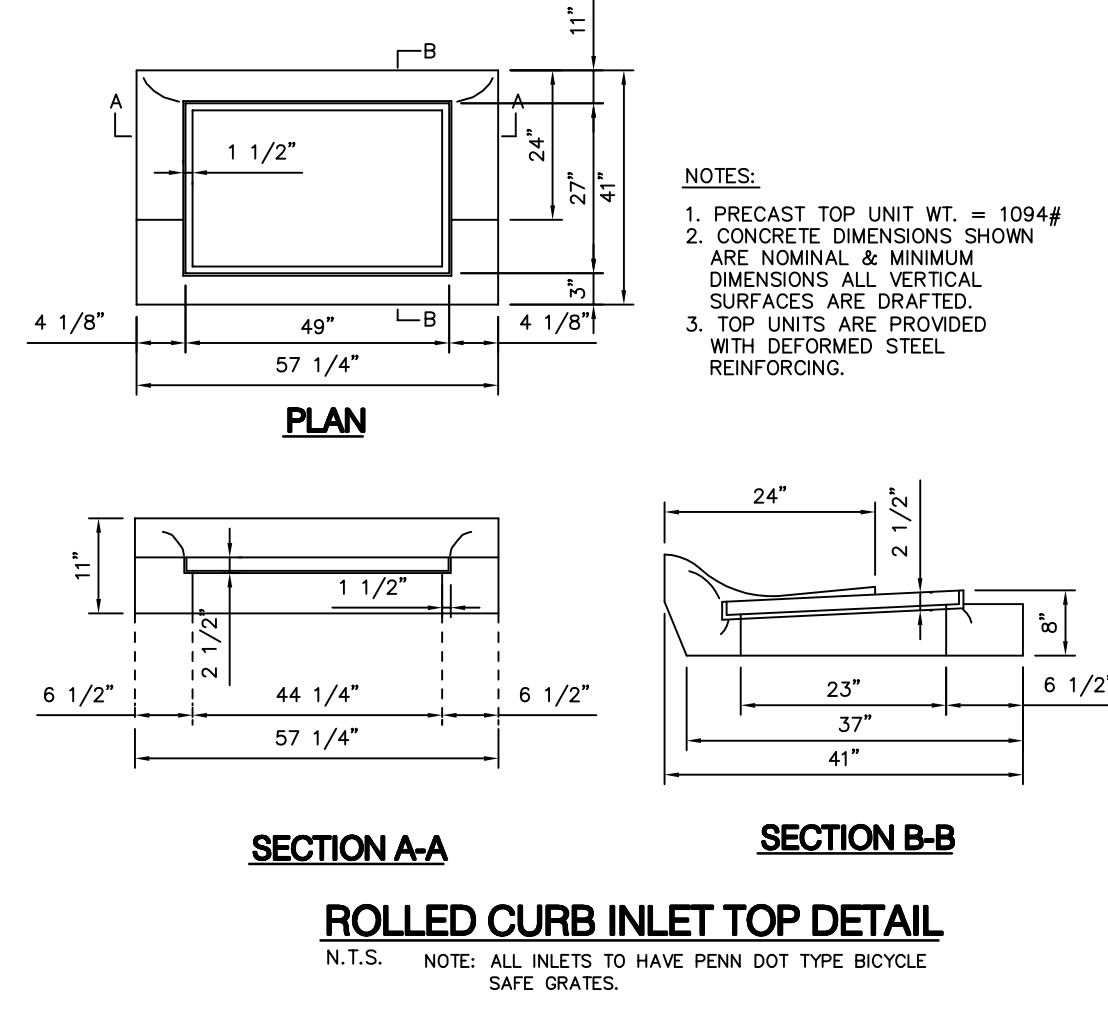
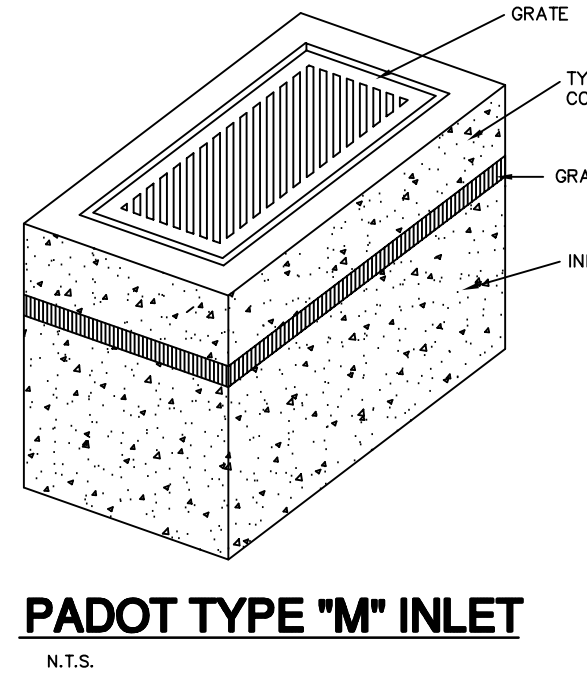
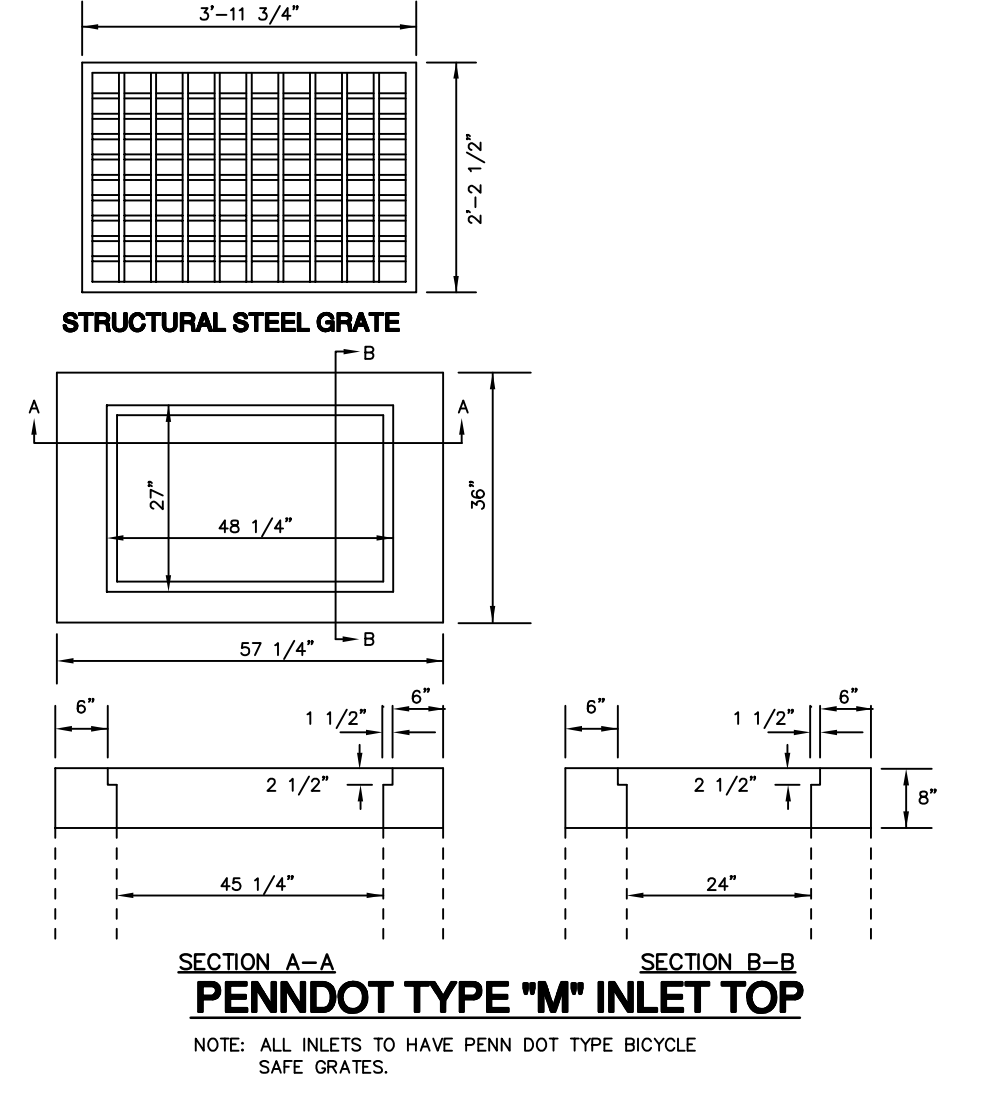
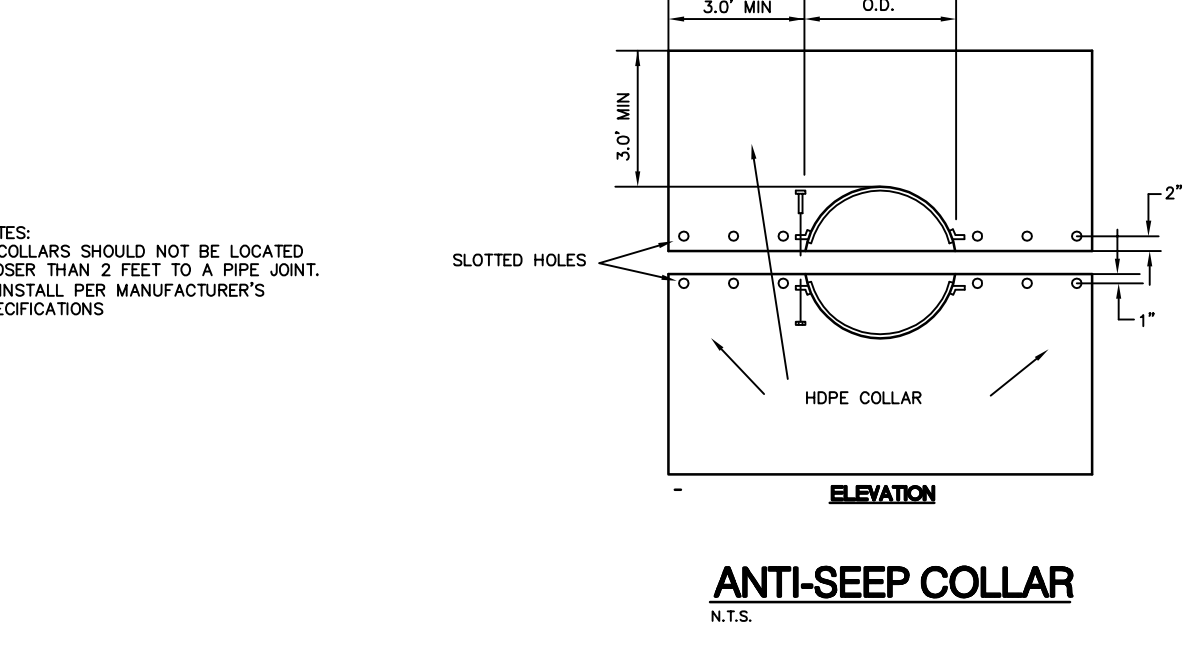

TYPICAL STORM INLET CONSTRUCTION

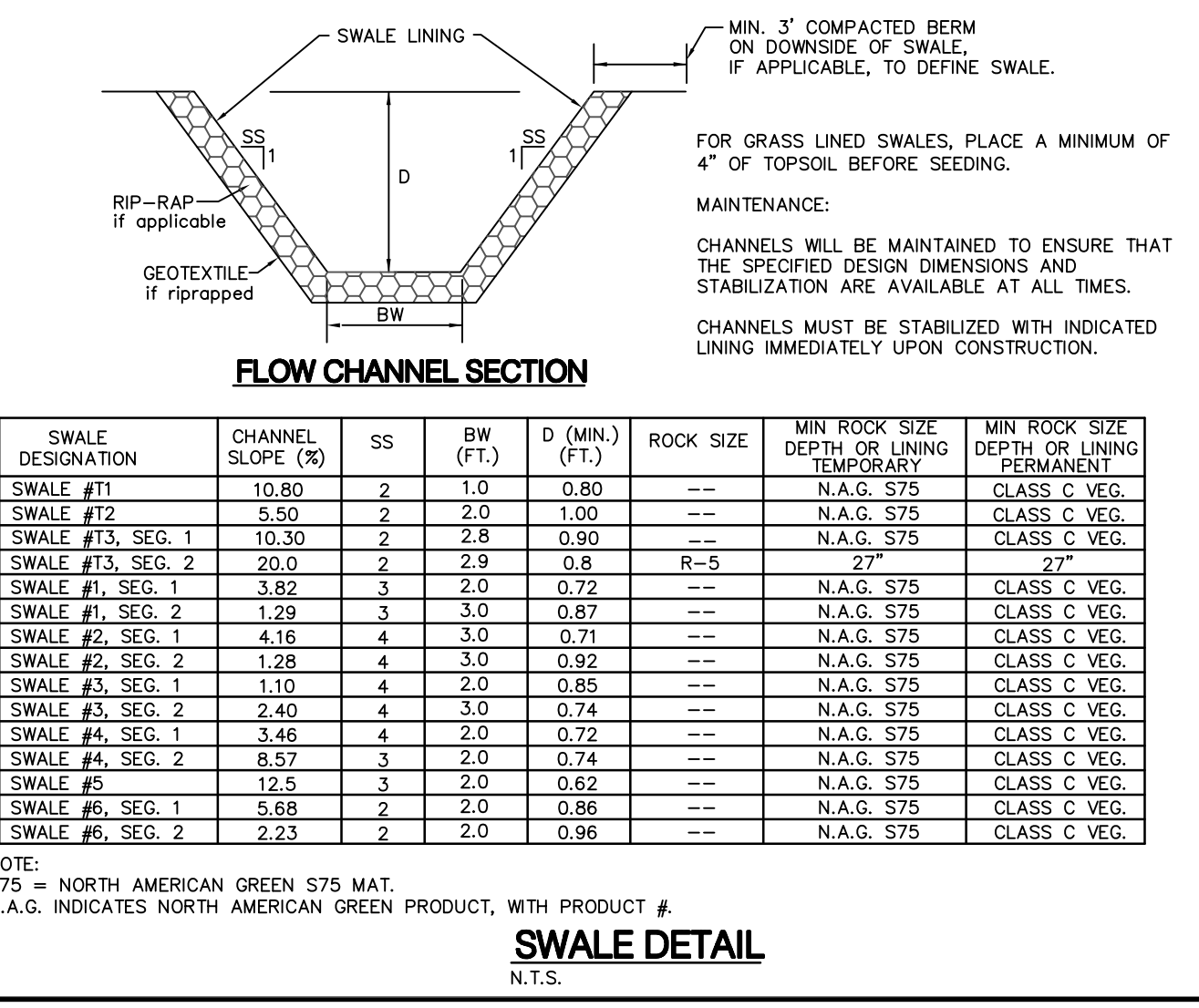
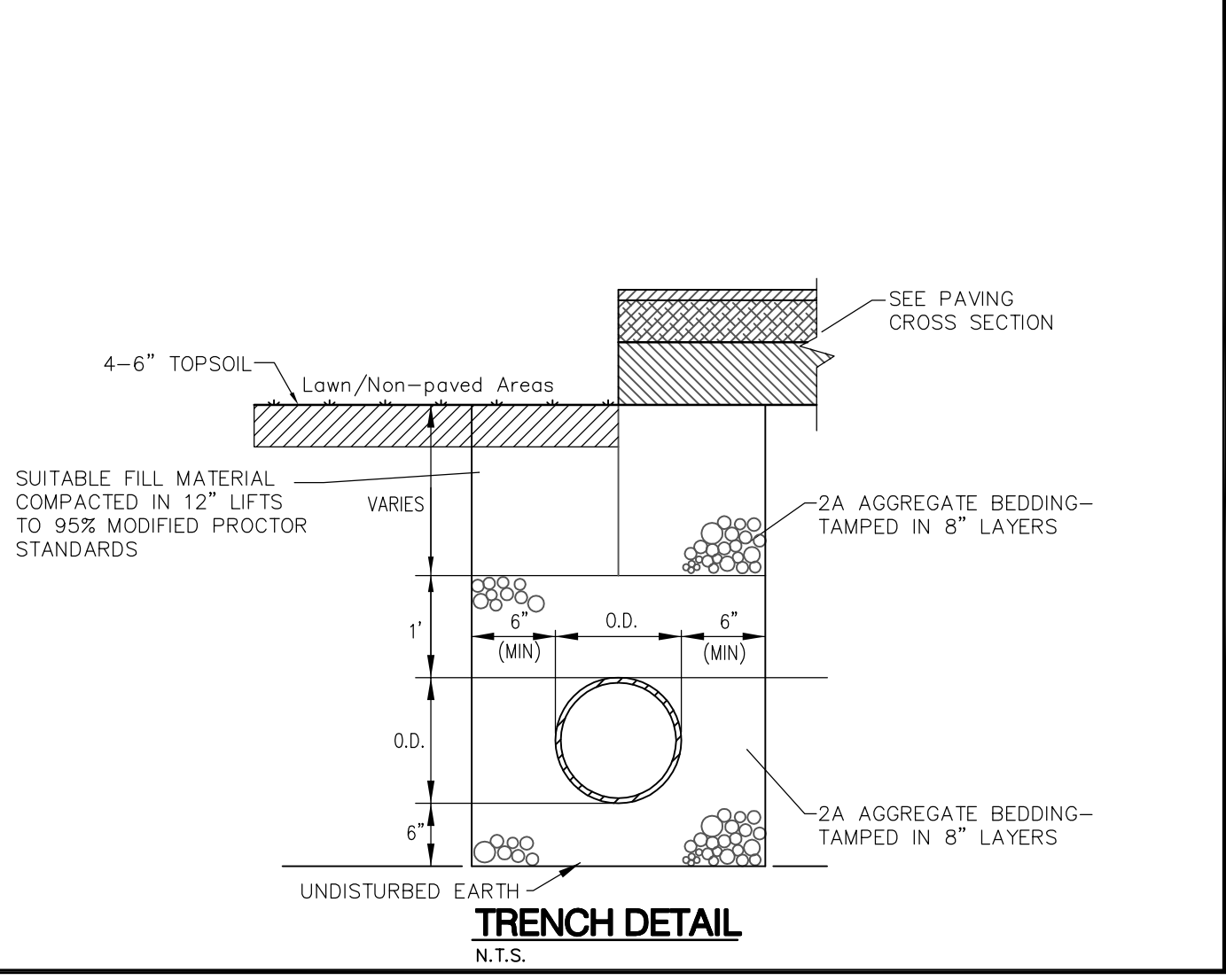
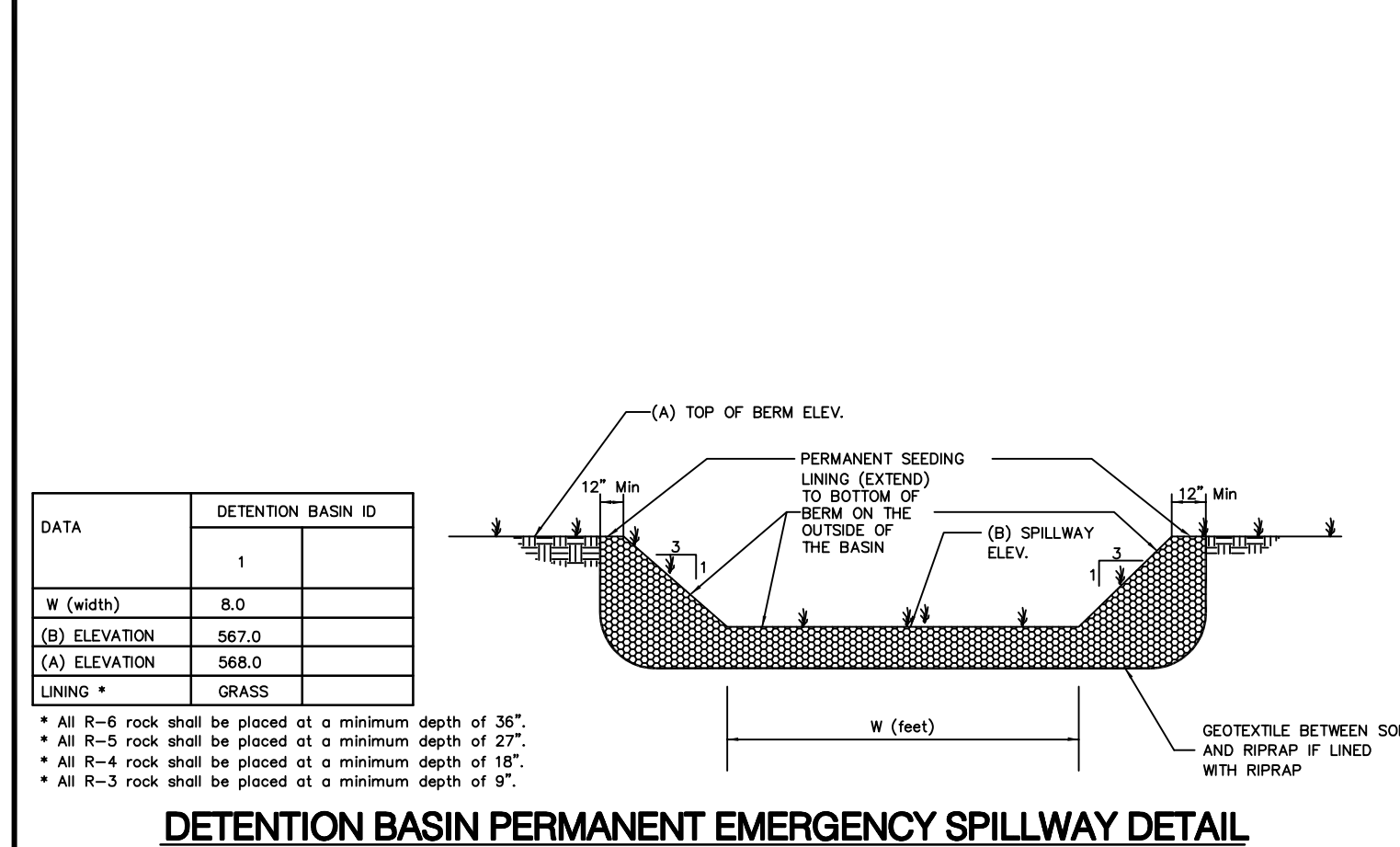
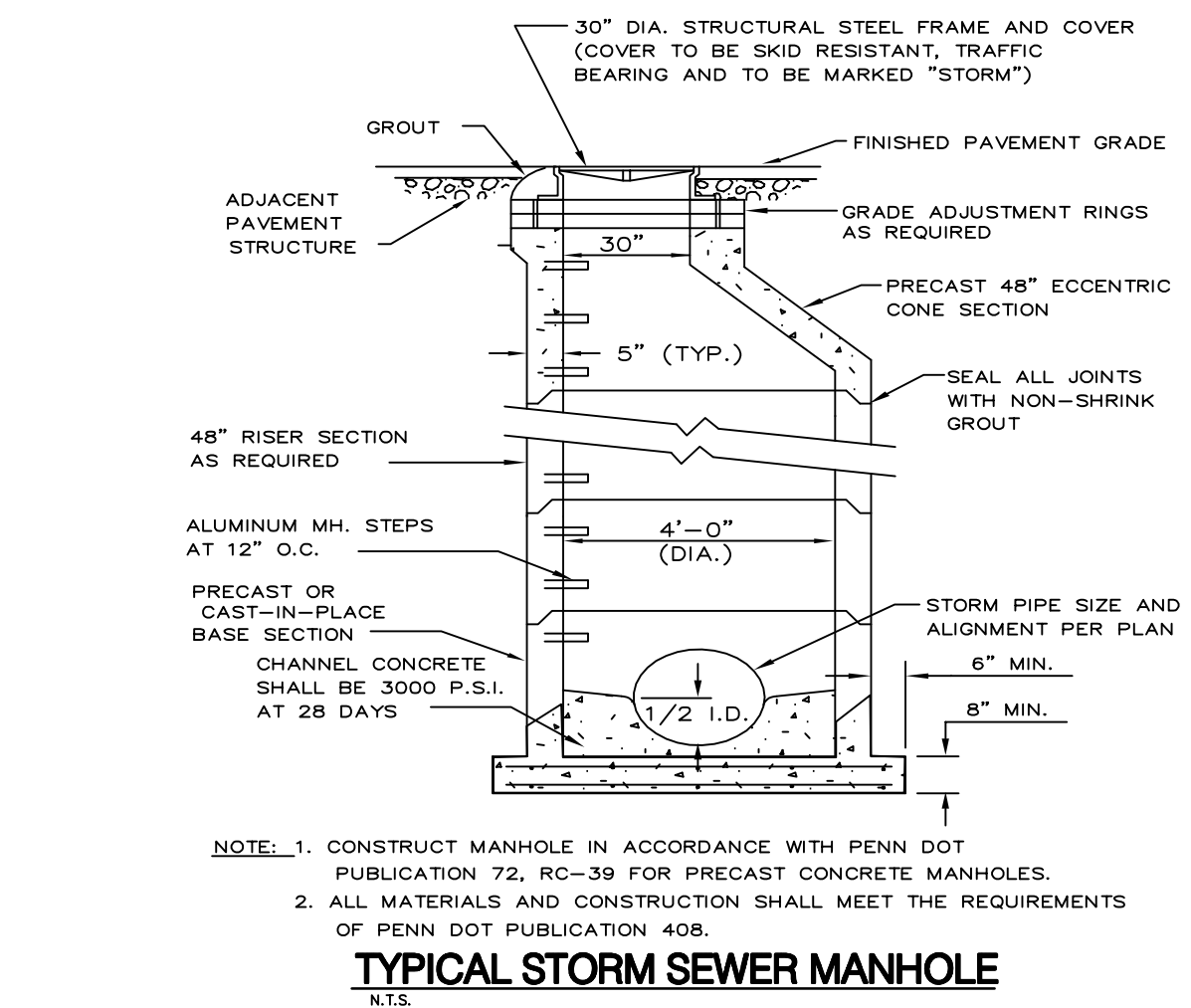

MISCELLANEOUS DETAILS FOR THE TERRACES AT SHEPHERDSTOWN

LOCATED IN UPPER ALLEN TOWNSHIP, CUMBERLAND COUNTY, PA.

DRAWING ID: 210014-DTL

DATE: 10/28/10

SHEET 10 OF 14